



## CURRENT PROBE CT6700/CT6701

Current Sensors



10× the sensitivity of conventional probes

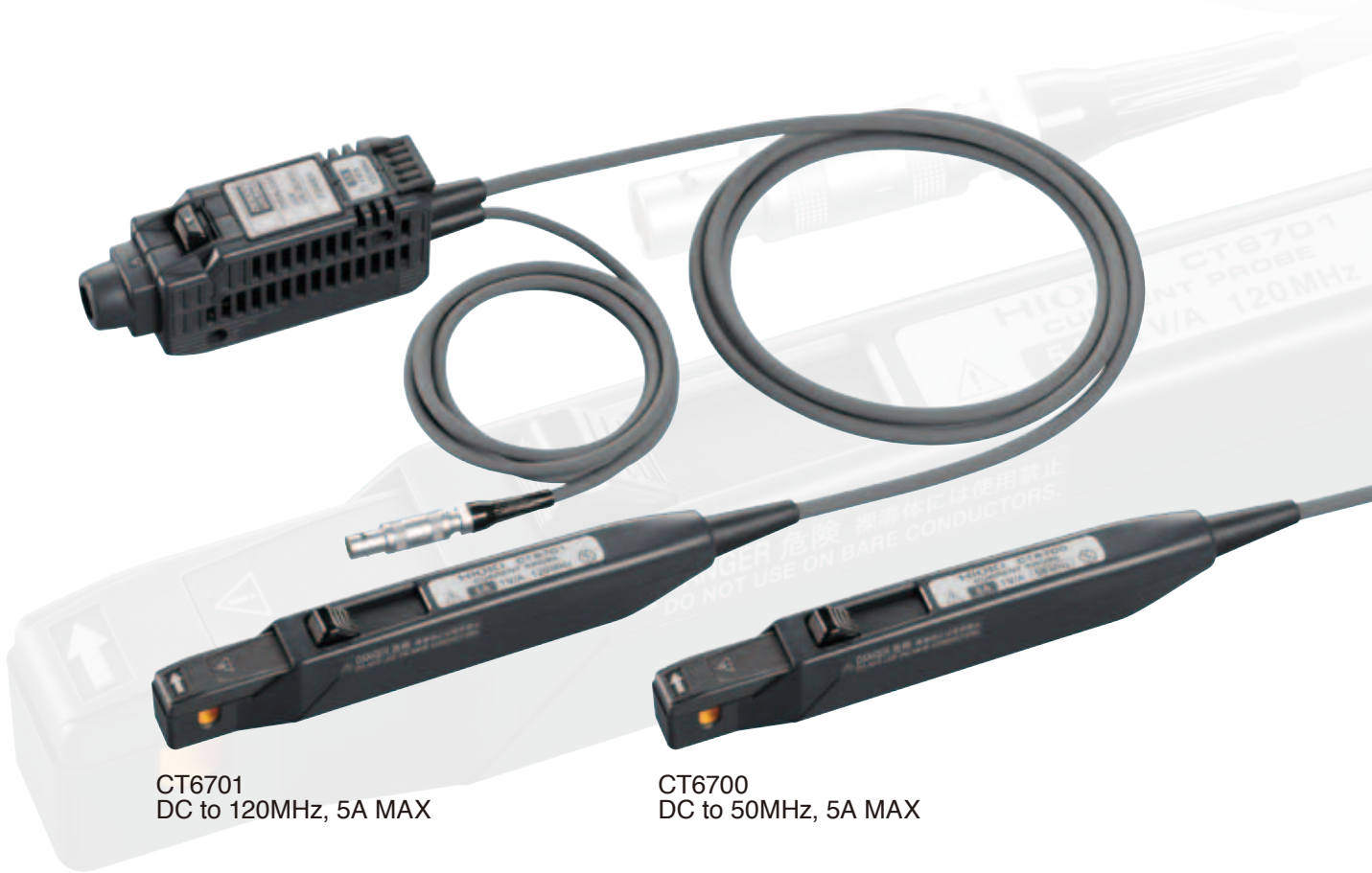

CT6701  
DC to 120MHz, 5A MAX

CT6700  
DC to 50MHz, 5A MAX

## Observe low current waveforms of 1 mA

Connection image



A separate power supply is required when using the CT6700/CT6701.

Current probes are key to the successful design of electrical devices, medical instruments, and electronic parts. In combination with an oscilloscope or HIOKI MEMORY HiCORDER, probes are ideal for measuring currents with high accuracy and wide bandwidths, making them indispensable tools for evaluating current consumption and control current. In recent years, customers are seeking current probes with high sensitivity to increase the accuracy of design and verification. To further enhance our rich lineup of current probes, HIOKI now delivers two new, highly-sensitive current probes that can measure low level currents from 1 mA.

# Analyze currents in finer detail



10x Sensitivity

Clearly observe even 1 mA waveforms

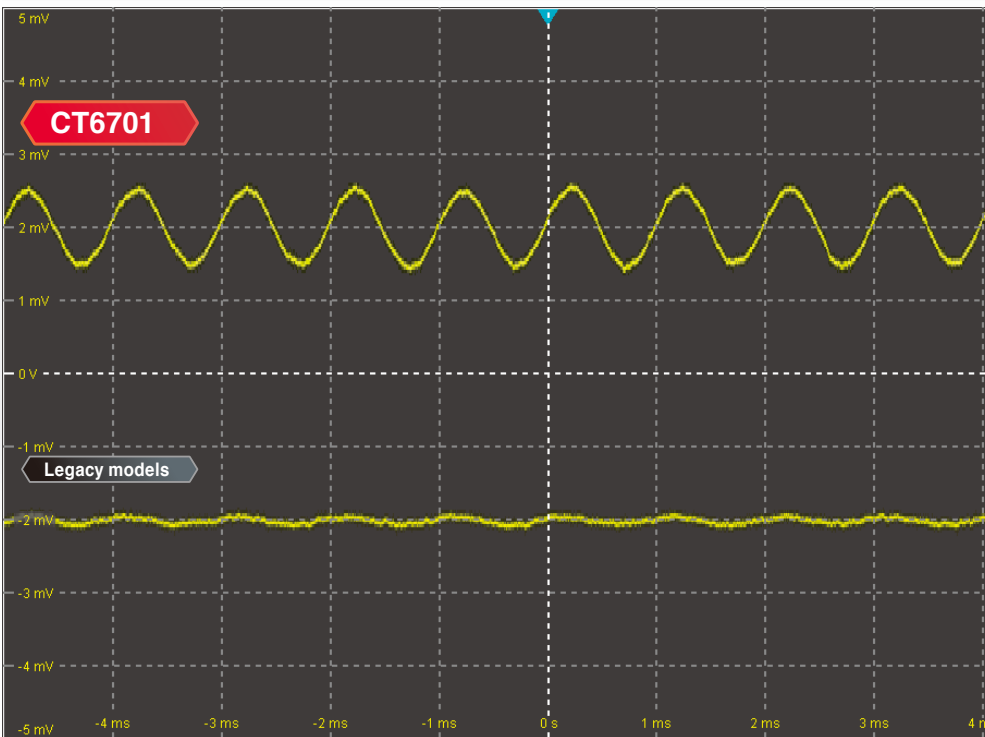

The output rate for the CT6700/CT6701 is 1 V/A. When 1 mA is measured, it can output 1 mV. This is ten times the sensitivity of our legacy\*1 models. Now, even 1 mA waveforms can be clearly captured.\*2

\*1: CURRENT PROBE 3273-50/3276  
Output rate 0.1 V/A, 30 A MAX

\*2: When measuring low level currents, in addition to noise from the current probe itself, there is also influence from external noise or noise from the connected meter.

Input:  
1 mAp-p, 1 kHz, sine wave  
Oscilloscope:  
Bandwidth 2 GHz  
(Bandwidth limit 20 MHz), 1 mV/div



Improved S/N Ratio: Measure even the extremely low current signals buried in noise

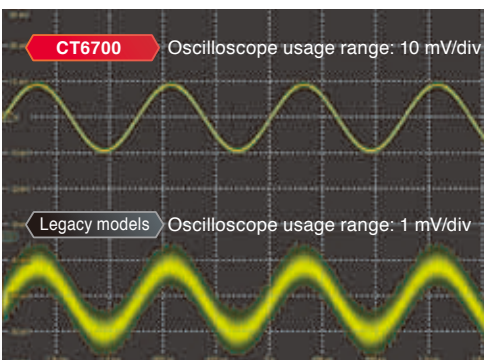

Input: 20 mAp-p, 1 kHz, sine wave  
Oscilloscope: Bandwidth 2 GHz (No bandwidth limitation),  
10 mV/div

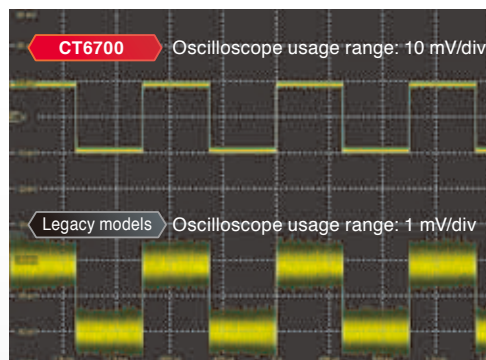

Input: 20 mAp-p, 1 kHz, square wave  
Oscilloscope: Bandwidth 2 GHz (No bandwidth limitation),  
10 mV/div

Low level currents can only be clearly captured by instruments that deliver a good S/N ratio. Because the output rate is now 1 V/A (10x than that of legacy models), you can observe waveforms even if the oscilloscope's range is 1/10 than that of legacy products. By allowing for range selection with leeway for the S/N ratio, you can clearly observe signals that previously were buried in noise.

# Streamlining Measurement

### Slim Sensor



Sensor (Actual size)

The sensor has been redesigned, making it more compact and easier to handle, in a form that fits perfectly in your hand. The ergonomic structure is ideal for situations with complex electrical circuit design and wiring.

### Warning Features

#### OVERLOAD Warning



Threshold - - - - -

Current

The warning lamp will flash if a current exceeding the rating is input.

#### JAW UNLOCKED Warning



"JAW UNLOCKED" will display and the warning lamp will light up if the sensor is unlocked when clamped.

### Automatic Zero-Adjustment and Demagnetization in One Button



With the CT6700/CT6701, you can automatically perform the zero-adjustment, which must be done before use, by pressing a single button.

By pressing and holding the button for demagnetization, you can cancel an offset margin of error after measuring a large current.

### One-touch Disconnection from the BNC Terminal

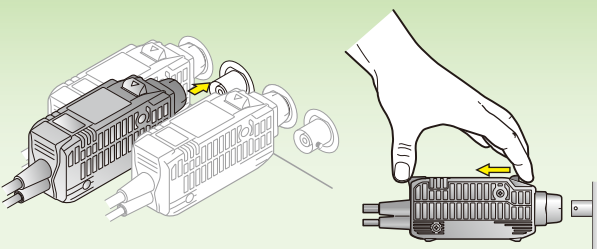

The BNC connector does not need to be rotated when connecting to an oscilloscope or recorder. Insert the connector until it automatically locks into place. To disconnect it, just pull the unlock lever toward you.

# Built for Demanding Applications

### Measure the current of automobile electronic parts

Observe control currents, which flow through automobile electronic parts such as compact motors, on the mA order.

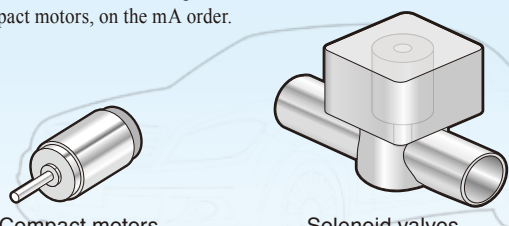

Compact motors      Solenoid valves

### Evaluate the current characteristics of circuit components

When testing for the correct functioning of built-in circuits, you can reliably catch noise waveforms with a wide frequency bandwidth.

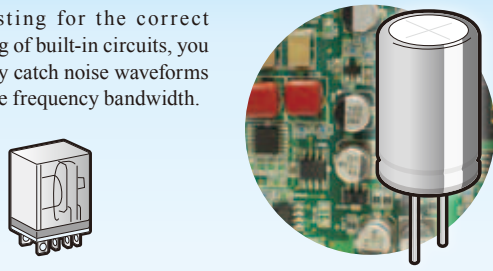

Relay control current      Condenser current

### Evaluate high-speed switching elements

Measure switching elements that drive devices such as LEDs and motors, including the ON/OFF response of semiconductors that operate at high speeds, ripple waveforms, and switching loss.

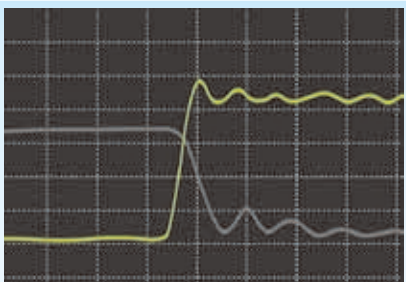
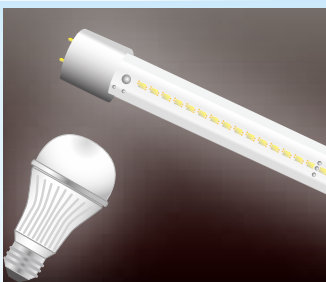
Waveform of an inverter when switched ON      Evaluation of LED light driving circuits



# Specifications

(Accuracy guaranteed for 1 year, Post-adjustment accuracy guaranteed for 6 months)

|                                                           | CT6700                                                                                                                                                       | CT6701                                                                     |
|-----------------------------------------------------------|--------------------------------------------------------------------------------------------------------------------------------------------------------------|----------------------------------------------------------------------------|
| Frequency range                                           | DC to 50 MHz (-3dB) (Refer to the frequency characteristics graph below.)                                                                                    | DC to 120 MHz (-3dB) (Refer to the frequency characteristics graph below.) |
| Rise time (10% to 90%)                                    | 7.0 ns or less                                                                                                                                               | 2.9 ns or less                                                             |
| Maximum rated current                                     | 5 A rms (DC, and sine wave) (Refer to the frequency derating properties graph below.)                                                                        |                                                                            |
| Maximum peak current                                      | ±7.5 A peak (non-continuous)                                                                                                                                 |                                                                            |
| Diameter of measurable conductors                         | 5 mm dia. or less                                                                                                                                            |                                                                            |
| Measurable conductors                                     | Insulated conductors                                                                                                                                         |                                                                            |
| Output voltage rate                                       | 1 V/A                                                                                                                                                        |                                                                            |
| Amplitude accuracy                                        | Typical ±1%rdg. ±1 mV, ±3.0%rdg. ±1 mV (DC, 45 to 66 Hz sine wave, 0 to 5 A rms)                                                                             |                                                                            |
| Output resistance                                         | 50 Ω ±10% (DC)                                                                                                                                               |                                                                            |
| Noise                                                     | 60 μA rms typical, 75 μA rms max (for 30 MHz band measuring instrument)                                                                                      |                                                                            |
| Temperature coefficient for sensitivity                   | ±2%rdg. or less (After automatic zero-adjustment with 50 Hz 5 A rms input, except at 23±5°C)                                                                 |                                                                            |
| Maximum rated power                                       | 3.2 VA (with continuous maximum input)                                                                                                                       |                                                                            |
| Supply voltage                                            | ±12 V                                                                                                                                                        |                                                                            |
| Operating temperature and humidity range                  | 0 to +40°C, 80% RH or less (no condensation)                                                                                                                 |                                                                            |
| Storage temperature and humidity range                    | -10 to +50°C, 80% RH or less (no condensation)                                                                                                               |                                                                            |
| Location for use                                          | Indoor, pollution degree 2, altitude up to 2000 m                                                                                                            |                                                                            |
| Effect of external magnetic fields                        | 20 mA max - DC and 60 Hz, magnetic field of 400 A/m                                                                                                          | 5 mA max - DC and 60 Hz, magnetic field of 400 A/m                         |
| Effect of radiated radio-frequency electromagnetic field  | ±10 mA max (at 3 V/m)                                                                                                                                        |                                                                            |
| Effect of conducted radio-frequency electromagnetic field | ±10 mA max (at 3 V)                                                                                                                                          |                                                                            |
| DEMAG/AUTO ZERO function                                  | Demagnetization, automatic zero-adjustment                                                                                                                   |                                                                            |
| JAW UNLOCKED detection                                    | LED lights up when the opening mechanism of the sensor head is unlocked.                                                                                     |                                                                            |
| OVERLOAD detection                                        | LED flashes to warn that the input is in excess of ratings                                                                                                   |                                                                            |
| Accuracy warranty period                                  | 1 year (Opening/closing up to 10,000 times)                                                                                                                  |                                                                            |
| Cord lengths                                              | Sensor cord: 1.5 m (4.92 ft), Power cord: 1.0 m (3.28 ft)                                                                                                    |                                                                            |
| External dimensions and mass                              | Sensor: 155 mm (6.10 in)W x 18 mm (0.71 in)H x 26 mm (1.02 in)D, Terminator: 29 mm (1.14 in)W x 83 mm (3.27 in)H x 40 mm (1.57 in)D mm, Mass: 250 g (8.8 oz) |                                                                            |
| Accessories                                               | Instruction manual, Carrying case                                                                                                                            |                                                                            |

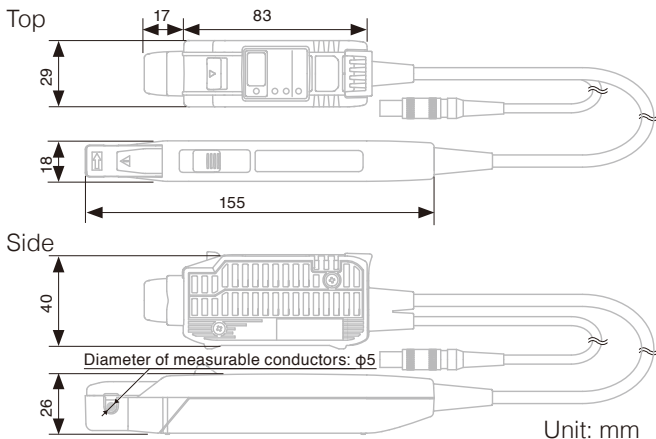
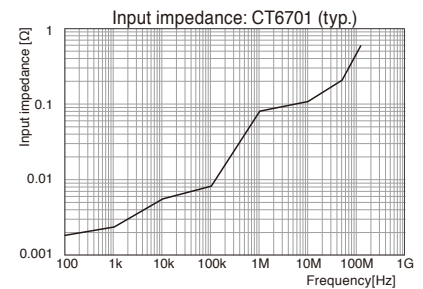
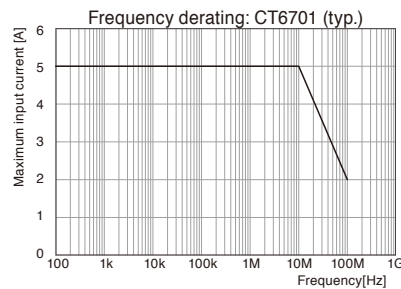
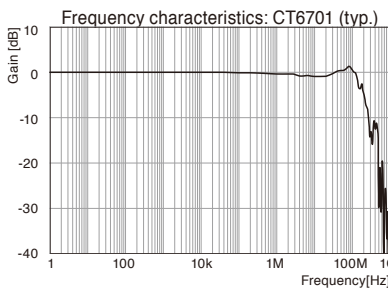
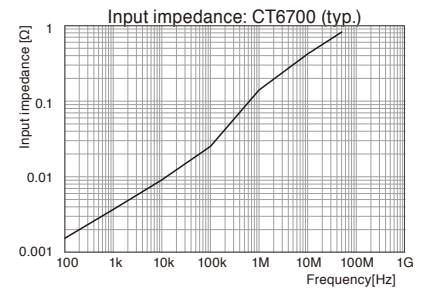
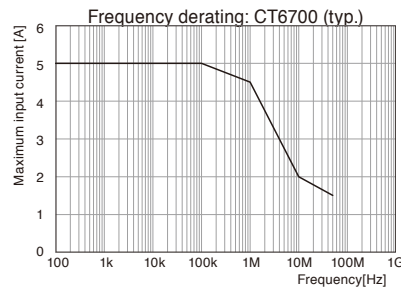
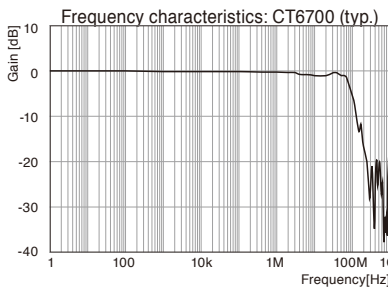

**Lineup and options**

**CURRENT PROBE CT6700**  
DC to 50MHz, 5A MAX

**CURRENT PROBE CT6701**  
DC to 120MHz, 5A MAX

**A separate power supply is required when using the CT6700/CT6701.**

**POWER SUPPLY 3269**  
Supports up to 4 current probes

**POWER SUPPLY 3272**  
Supports 2 current probes

\*About the 3272 Power Supply  
When using CT6700/CT6701 and a different sensor simultaneously, please note that you may not be able to use two sensors at once depending on the current consumption. Please check the specifications of the corresponding sensor.

Note: Company names and Product names appearing in this catalog are trademarks or registered trademarks of various companies.



HEADQUARTERS  
81 Koizumi, Ueda, Nagano, 386-1192, Japan  
TEL +81-268-28-0562 FAX +81-268-28-0568  
http://www.hioki.com / E-mail: os-com@hioki.co.jp

DISTRIBUTED BY



**태신상사 주식회사**

서울특별시 서초구 강남대로 309 코리아비즈니스센터 1703호  
TEL 02-3474-0070 FAX 02-3474-0059